

# Elasticity, Tear Strength, and Strength of Adhesion of Soft PVC Gels

A. N. GENT AND N. SHIMIZU,\* *Institute of Polymer Science,  
University of Akron, Akron, Ohio 44325*

## Synopsis

An experimental study is described of the tensile modulus  $E$  of elasticity, tear strength  $G_c$ , and strength  $G_a$  of adhesion to a Mylar substrate, for PVC gels prepared with a wide range of PVC concentrations and with four different plasticizers. The modulus  $E$ , measured under quasiequilibrium conditions, was found to be approximately proportional to  $c^3$ , where  $c$  is the volume concentration of PVC. The tensile behavior suggests that the molecular strands comprising the undiluted elastic network are relatively short, only about 26 C atoms long.  $G_c$  under threshold conditions was found to vary with  $c^{2.25}$  and to be considerably larger than (about  $10 \times$ ) the value expected for a molecular network of short PVC chains. This difference is attributed to yielding of crystallites before molecular rupture can take place. Adhesion of PVC gels to Mylar was relatively weak. Both the tear strength and strength of adhesion were strongly dependent upon rate of fracture propagation and temperature, in good accord with the WLF rate-temperature equivalence for simple glass-forming substances. Thus, the strength of PVC gels appears to be determined largely by the glass temperature of the composition, and not by the amount or type of plasticizer except insofar as they affect the glass temperature.

## INTRODUCTION

Polyvinyl chloride (PVC) gels are widely used as flexible solids and compliant coatings. They show an ability to deform and recover in a substantially elastic manner, like cross-linked elastomers, even though they lack permanent intermolecular bonds. It is generally assumed that parts of the PVC molecules associate together into microcrystalline domains, which act as crosslinks, when a mixture of PVC and a suitable plasticizer is cooled from the "fusion" temperature to ambient temperature. This gelation process is found to be reversible: on heating to a sufficiently high temperature, the gel loses its strength and stiffness again.

Although PVC gels have been widely employed for many years, relatively few studies of their physical properties have been reported. In a thorough study of the effects of type and concentration of plasticizer upon the modulus of elasticity of the resulting gel, Walter showed that the amount of plasticizer had a large effect on the modulus of the gel, but, on an equal-volume basis, the type of plasticizer incorporated had little effect.<sup>1</sup> An approximately linear relationship was observed to hold between the logarithm of the tensile Young's modulus  $E$  and the logarithm of the volume fraction  $c$  of PVC in the plasticized gel:

$$\log_{10} E = \eta \log_{10} c + \log_{10} E_o \quad (1)$$

\*On leave of absence from Denki Kagaku Kogyo K. K., Niigata-ken, Japan, 1983-85.

where  $\eta$  and  $E_0$  are constants. Relations of this general form were found to hold for various plasticizers over a wide range of values of  $c$ , from close to the gel point concentration (2–20% by volume of polymer, depending upon the solvent power of the plasticizer) up to about 30% by volume of the polymer. Above 30%, the relations obtained between  $\log E$  and  $\log c$  were no longer linear.

For 18 plasticizers, the index  $\eta$  ranged from about 3.1 to 3.9, with an average value of 3.45, and the extrapolated value  $E_0$  of the modulus in the unplasticized state was found to be approximately 50 MPa. As Walter pointed out, this value is rather high for an undiluted elastomeric network. It corresponds to an average molecular weight for a network strand of only about 200 g/mole, corresponding to only about 6.5 main-chain atoms between junction points. However, there are at least three reasons why rubber network considerations may not apply directly. The PVC junctions themselves consist of small crystallites which will act as reinforcing (stiffening) inclusions as well as crosslinks.<sup>2</sup> The molecular strands between them may be stretched taut by the forces of crystallization so that the assumption of relaxed configurations in the unstressed state becomes invalid.<sup>3</sup> And the measurements at high concentrations of PVC may not have been carried out under equilibrium conditions. Walter made measurements of  $E$  at a fixed time interval after loading, approximately 1 min at 30°C, and this may well be inadequate for materials having glass transition temperatures not much below the test temperature. Some independent measurements of  $E$  are described below for PVC gels prepared with several plasticizers over a wide range of concentration. They are then compared with Walter's results and with the predictions of the theory of rubberlike elasticity.

A second remarkable property of PVC gels is their resistance to tearing. In view of the high degree of dilution commonly used, only about 25% of the gel consisting of PVC and the remainder being a mobile fluid, it is quite surprising that the tear strength is relatively high, comparable to that of a conventional rubbery solid. Little previous work appears to have been published on this feature of PVC gels. An experimental study has therefore been carried out, using various concentrations of selected plasticizers. Values of the tear strength, characterized by the work  $G_c$  required to propagate a tear through unit area of the gel, have been determined over wide ranges of tear rate and test temperature. The results are described in the second part of this paper.

Finally, some observations are reported of the strength of adhesion of soft PVC gels to an inert substrate, a Mylar film. Again, measurements have been made over wide ranges of speed of detachment and test temperature. These results are then compared with corresponding values of the intrinsic strength of the gel, given by the tear strength at the same rate and temperature. In this way, estimates can be made of the contribution of bulk properties of soft compliant layers to their strength of adhesion.

## EXPERIMENTAL PROCEDURES

**Preparation of Test Samples.** Powdered PVC (Geon 121, B. F. Goodrich Chemical Company) was mixed by hand with a plasticizer in the required proportions to form a slurry. The mixture was subjected briefly to a vacuum

TABLE I  
Glass Transition Temperatures of PVC Gels Determined by  
Differential Scanning Calorimetry at 10°C/min

Plasticizer	PVC concentration, <i>c</i> (percent by volume)	$T_g$ (°C)
(None)	100	65
DOP	0	-85
	15	-60
	25	-50
	50	-10
	0	-100
DOS	15	-78
	25	-62
	50	-18
	0	-88
DBP	15	-60
	25	-46
	50	-11
	0	-55
TCP	15	-45
	25	-35
	50	+2
	0	-55

to remove dissolved air and then poured into an open mold and heated first for about 20 min at 100°C and then for between 2 and 6 min at "fusion" temperatures between 170°C and 180°C. The powdered PVC dissolved in the plasticizer under these circumstances, and a clear elastomeric sheet was obtained on cooling to room temperature. Test strips about 10-mm wide and 80-mm long were cut from the sheets, which were generally about 1-mm thick.

The plasticizers used were dioctylphthalate (DOP), dioctyl sebacate (DOS), dibutyl phthalate (DBP), and tricresyl phosphate (TCP). They were generally mixed with PVC in the following volume concentrations: 50, 75, and 85%. A wider range of concentrations was employed with DOP, ranging from 25 to 90% by volume. Values of the glass transition temperature  $T_g$  for each composition, determined by differential scanning calorimetry, are given in Table I.

**Measurement of Young's Modulus  $E$ .** Experimental relations between tensile engineering stress  $\sigma$ , given by the applied tensile force per unit of unstrained cross-sectional area, and strain  $e$  were determined at a strain rate of about  $2 \times 10^{-3} \text{ sec}^{-1}$ , at temperatures of 25 and 75°C. They were found to be surprisingly linear, up to a strain of about 1 unit (100% extension), as shown in Figure 1, and were reversible from strains of this magnitude, showing little permanent set, less than 5%. Values of Young's modulus  $E$  were obtained from the initial slopes of these tensile stress-strain relations.

**Measurement of Tear Strength  $G_c$ .** Test strips were cut about two-thirds of the way through along the center line, leaving about one-third of the original thickness to be torn through. This procedure prevented the tear from deviating from a straight path when a tear force  $F$  was applied to each half of the strip, as shown in Figure 2(a). In addition, a layer of thin cotton cloth was embedded into the stiffer gels before they fused so that the torn parts of the

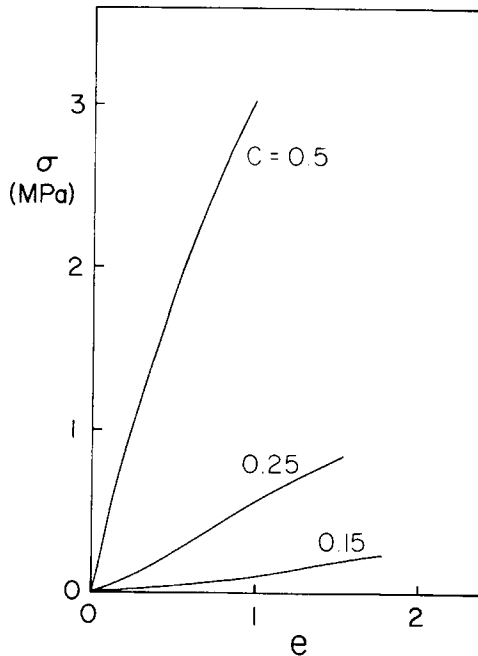

Fig. 1. Experimental relations between tensile stress  $\sigma$  and elongation  $e$  for PVC/DOP gels having various volume concentrations  $c$  of PVC.

strip would not be stretched significantly by the tear force  $F$ . The tear strength  $G_c$  is given by Rivlin and Thomas<sup>4</sup>

$$G_c = 2F/t \quad (2)$$

where  $F$  is the average value of the force required to propagate the tear and  $t$  is the thickness actually torn through, determined subsequently by examining the torn surfaces. Measurements were made in this way over a wide range of rates  $R$  of tear propagation, varying from  $9 \times 10^{-6}$  to  $9 \times 10^{-3}$  m/s, and at various temperatures in the range  $-20$  to  $+90^\circ\text{C}$ .

**Measurement of Strength  $G_a$  of Adhesion.** As in tearing, the strength of adhesion can be characterized by the work  $G_a$  required to pull apart a unit area of the interface between two adhering layers. In terms of the mean value of the force  $F$  applied to peel back at  $180^\circ$  a flexible layer from a rigid substrate, Figure 2(b), the strength of adhesion is given by

$$G_a = 2F/w \quad (3)$$

where  $w$  is the width of the interface.

Test samples were prepared by pressing a layer of a soft compliant PVC gel into intimate contact with a film of Mylar<sup>®</sup> (Type 300A, E. I. du Pont de Nemours & Co.), held rigid by cementing it to a steel backing plate. Again, when the peel forces were large the adhering PVC layer was reinforced with a thin cloth backing to minimize any extension that might be imposed on the peeled section by the peel force. When the peel forces were small, insufficient to bend the peeled section through  $180^\circ$ , then an additional constraint was

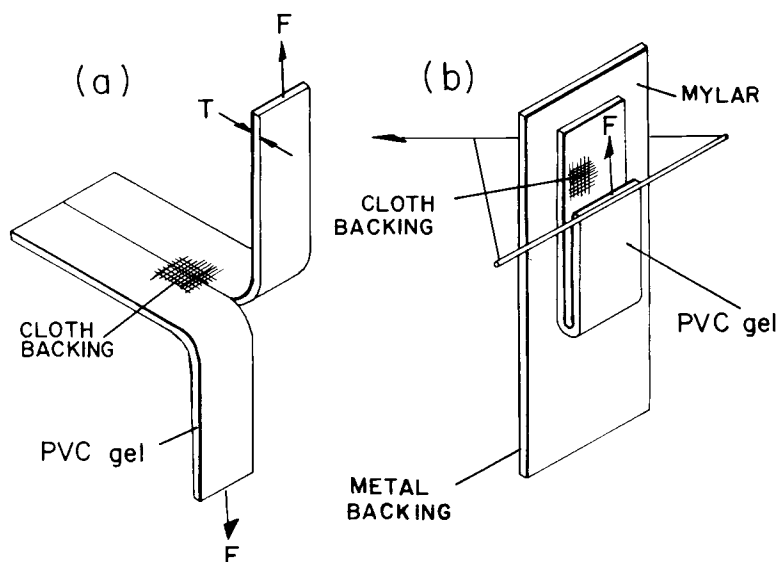

Fig. 2. Methods of measuring: (a) tear strength, (b) strength of adhesion.

applied at right angles to the direction of peeling as shown in Figure 2(b),<sup>5</sup> to hold the peeled strip in the fully bent configuration during peeling.

## EXPERIMENTAL RESULTS AND DISCUSSION

**Values of Young's Modulus  $E$  for Gels of Various PVC Concentrations.** Experimentally determined values of Young's modulus  $E$  for PVC gels plasticized with dioctyl phthalate (DOP) are plotted in Figure 3 against the volume concentration  $c$  of PVC in the gel. In view of the wide range, logarithmic scales have been employed for both axes. Results are shown for two temperatures: 25°C (open circles) and 75°C (closed circles). Results obtained by Walter<sup>1</sup> at 30°C are represented by triangles. Results obtained by Bullman and Hunston<sup>6</sup> for the limiting value of the dynamic shear modulus  $G$  at zero frequency have been multiplied by  $3 \times$  to convert them into corresponding values of Young's modulus  $E$ : they are represented by open squares in Figure 3.

Good agreement is seen to hold between these various measurements at 25–30°C. At 75°C the values of  $E$  are distinctly lower, especially at higher concentrations of PVC. This difference is attributed to a closer approach to equilibrium at 75°C. Note that Walter's measurements, made at 30°C after only 1 min under load, yield an extremely high value for  $E$  for the most concentrated gel, a leathery solid rather than an elastomeric material.

The upper straight line in Figure 3 has a slope of 3.5, in accord with Walter's results, and extrapolates to a value of  $E_o$  for undiluted PVC in the elastomeric state of about 40 MPa. The lower straight line, believed to represent more accurately the equilibrium behavior of elastomeric gels, has a slope of 3.0 and extrapolates to a lower value for  $E_o$ , of about 14 MPa. This value is still unexpectedly large, however, corresponding to an average molecu-

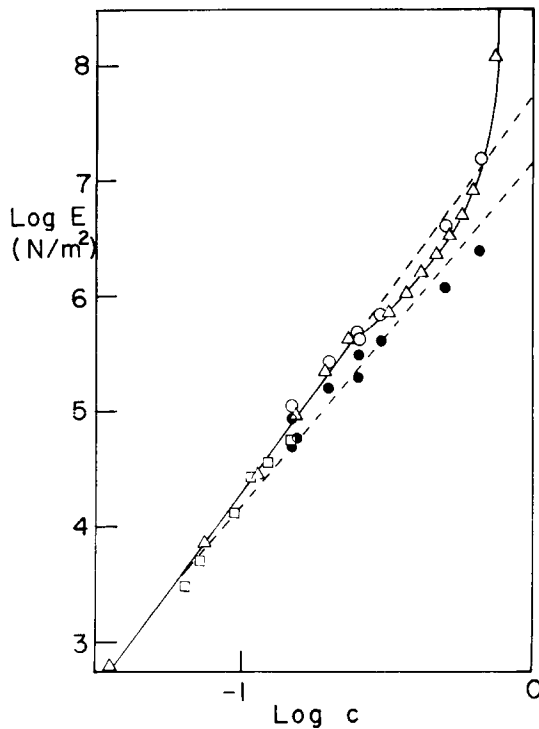

Fig. 3. Tensile (Young's) modulus  $E$  vs. volume concentration  $c$  of PVC in PVC/DOP gels. Open circles: measured at 25°C. Filled-in circles: measured at 75°C. Triangles: results at 30°C reported by A. T. Walter.<sup>1</sup> Squares: extrapolated values of  $3G'$  at zero frequency, obtained by G. W. Bullman and D. L. Hunston.<sup>6</sup>

lar weight per network strand of only about 800 g/mole, i.e., only about 26 main-chain atoms between junction points.

Other evidence for the network strands being unusually short is afforded by the stress-strain relations (Fig. 1). In some cases they show upward curvature at strains of about unity or less. This feature is not usually encountered in cross-linked elastomers until much larger extensions are imposed and occurs when the molecular strands are pulled nearly taut.<sup>7,8</sup> At lower strains the stress-strain relations curve downward, as predicted by the statistical theory of rubberlike elasticity.<sup>8</sup> Thus, the shapes of the stress-strain relations for PVC gels also suggest that the molecular strands in them are relatively short and reach a taut configuration at low extensions.

Even under equilibrium conditions, the dependence of Young's modulus  $E$  upon PVC concentration  $c$  in the gel is unexpectedly strong:  $E \propto c^3$ . Bimolecular associations between chains would be expected to vary with  $c^2$ . Thus there appears to be an extra stiffening effect, possibly due to the crystallites acting as reinforcing particles in the gel, in addition to their main role as molecular interconnections. Alternatively, at low concentrations many of the molecular strands may be elastically ineffective because they form closed loops, for example, and are not part of the continuous molecular network. If the proportion of such elastically ineffective strands decreases as the concentration of PVC in the gel is increased (as would be expected) a disproportionate increase in Young's modulus would be observed.

**Tear Strength  $G_c$ .** Experimentally determined values of tear strength (fracture energy)  $G_c$  are plotted in Figure 4 against the rate  $R$  of crack propagation for samples of a 25/75 PVC/DOP gel. Measurements were made at several temperatures in the range 0–90°C. The results are seen to vary widely, from less than 10 J/m<sup>2</sup> at low rates of tearing and at high temperatures up to about 2000 J/m<sup>2</sup> at high rates of tearing and low temperatures.

This form of rate and temperature dependence is characteristic of a rubbery solid in the transition from a rubber to a glass.<sup>9</sup> By using a scaling factor  $a_T$  to calculate the effective rate of tearing  $Ra_T$  at the glass transition temperature  $T_g$ , where  $a_T$  is given by the WLF relation:<sup>10,11</sup>

$$\log a_T = -17.5(T - T_g)/(52 + T - T_g) \quad (4)$$

measurements at different temperatures can often be brought into agreement.<sup>9</sup> Indeed, the success of this procedure indicates that the principal effect of changing the test temperature is to change the rate of motion of molecular segments, and that this variable is the primary cause of the observed rate and temperature dependence.<sup>9</sup>

In the same way the present measurements were found to superpose when plotted against  $Ra_T$  where  $a_T$  was calculated by means of Eq. (4) using the measured glass transition temperature for the particular gel being examined (Table I). Results for DOP gels are shown in Figure 5; similar relations were obtained for all of the gels studied.

It is noteworthy that at relatively high effective rates of tearing, greater than about 10<sup>-14</sup> m/s, the results for gels of different plasticizer concentration superimposed on each other. Only at low effective rates of tearing were clear differences noted. Under these conditions, the lower the PVC concentration the lower was the measured tear strength. The effects of type and amount of plasticizer present in the gel are now discussed separately.

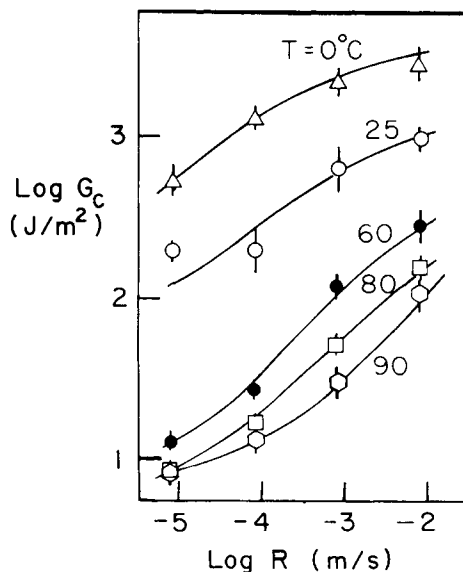

Fig. 4. Fracture energy  $G_c$  for a 25/75 PVC/DOP gel plotted against the rate  $R$  of tear propagation.

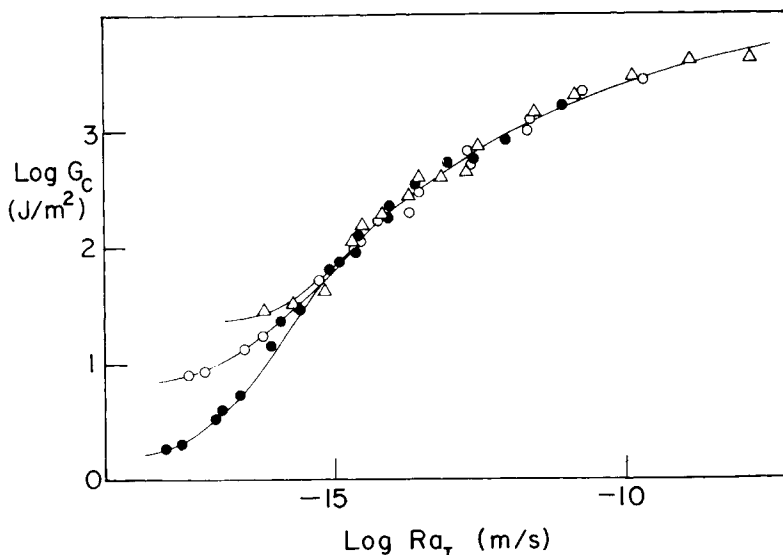

Fig. 5. Fracture energy  $G_c$  of PVC/DOP gels having various volume concentrations  $c$  of PVC, plotted against the effective rate  $Ra_T$  of tear propagation at their respective glass transition temperatures.  $c = 0.15$ , ●;  $c = 0.25$ , ○;  $c = 0.5$ , Δ.

**Effect of Type of Plasticizer Upon  $G_c$ .** Although at one particular rate of tear propagation and at one particular test temperature, values of  $G_c$  for gels prepared with different plasticizers were found to be quite different in magnitude, even when the same volume concentration of PVC was used in each gel, these variations largely disappeared when the results were referred to the respective glass transition temperature of each gel. In Figure 6, experimental results for  $G_c$  are plotted against the effective rate of tearing  $Ra_T$  at the appropriate glass transition temperature for 25/75 volume concentrations of PVC in gels prepared with four plasticizers. The relations obtained are seen to be of similar form, increasing from an initial value for  $G_c$  of about 6 J/m<sup>2</sup> at low effective rates of tearing, independent of the type of plasticizer used, up to a maximum value of about 3000 J/m<sup>2</sup> at high effective rates of tearing, again independent of the plasticizer type. Indeed, the lateral separations of the experimental relations shown in Figure 6, amounting to a factor of about  $50 \times$  at most, might well arise solely from experimental errors in determining  $T_g$  for the various gels.

Thus, we conclude that the tear strength of PVC gels over wide ranges of test temperature and rate of tearing is determined principally by the rate of segmental motion, as for elastomeric networks.<sup>9</sup> The principal effect of the type of plasticizer employed is to change the glass transition temperature of the resulting gel and hence the segmental mobility of the PVC network at any higher temperature. Presumably the mechanism of strengthening is by adding to the intrinsic strength of the molecular network, discussed in the following section, contributions from energy expended in viscous processes as the molecular strands are straightened and fractured.

**Effect of Amount of Plasticizer Upon  $G_c$ .** At high effective rates of tearing the main effect of the amount of plasticizer present in the gel is on the



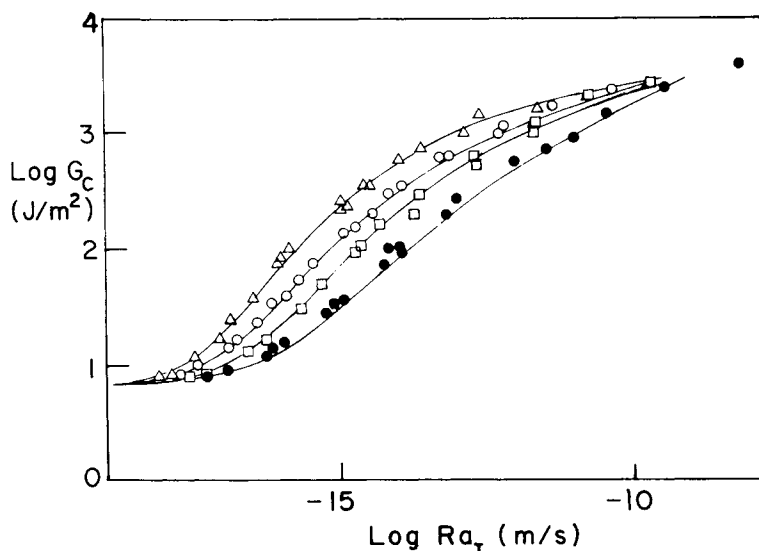

Fig. 6. Fracture energy  $G_c$  of PVC gels having a volume concentration of PVC of 25% with each of four different plasticizers, plotted against the effective rate  $Ra_T$  of tear propagation at their respective glass transition temperatures. DOS,  $\Delta$ ; DBP,  $\circ$ ; DOP,  $\square$ , TCP,  $\bullet$ .

glass transition temperature  $T_g$ . When allowance is made for this, the values obtained for  $G_c$  are virtually identical (Fig. 5). However, at low rates of tearing the tear strengths of gels having lower concentrations of PVC are substantially reduced (Fig. 5). By extrapolation to zero rate of tear propagation, threshold values of the fracture energy, denoted  $G_{c,o}$ , may be determined. These values are taken here as measures of the intrinsic strength of the molecular network in the absence of reinforcement due to viscous processes. They appear to be independent of the type of plasticizer incorporated (Fig. 6), but strongly dependent upon the amount (Fig. 5).

Best estimates of  $G_{c,o}$  are plotted in Figure 7 against the concentration  $c$  of PVC in the gel, using logarithmic scales for both axes. Linear relations are shown in Figure 7 having slopes of 2.0 and 2.5: the best fit seems to lie somewhere in between. Thus, the present experimental results can be described by the approximate relation

$$\log_{10} G_{c,o} = m \log_{10} c + \log_{10} G_{c,o}^* \quad (5)$$

where  $m = 2.25 \pm 0.25$  and  $G_{c,o}^*$  denotes the threshold tear strength of an undiluted elastomeric PVC network, and takes the value:  $135 \pm 35 \text{ J/m}^2$ .

Considering first the extrapolated value  $G_{c,o}^*$ , we note that this is substantially higher than the threshold tear strengths usually observed for elastomeric networks, which range from about  $20 \text{ J/m}^2$  to  $80 \text{ J/m}^2$  depending upon the molecular mass per main-chain atom and the average length of a network strand.<sup>12</sup> Indeed, because the molecular mass per main-chain atom is relatively large for PVC, about 31 a.m.u., and the effective length of network strands has been inferred from the elastic properties to be relatively short, about 3.2 nm, we would expect the threshold fracture energy of PVC to be

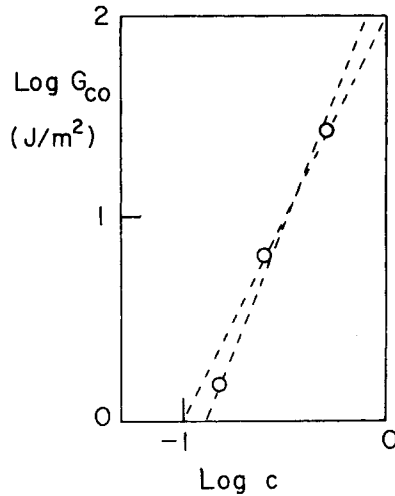

Fig. 7. Threshold fracture energy  $G_{c,0}$  vs. volume concentration  $c$  of PVC in the gel.

quite small, only about  $10 \text{ J/m}^2$ .<sup>12</sup> Thus, the anomaly is particularly striking when PVC gels are compared with covalently cross-linked molecular networks of similar density and strand length.

It probably reflects a different mechanism of failure in the two cases. For PVC gels, the crystallites which act as molecular interconnections are probably pulled apart at high stresses without the component molecules undergoing rupture. This is a dissipative process, and also a mechanism of stress redistribution, not available in covalently-bonded molecular networks, so that a higher value of fracture energy would be expected for PVC gels.

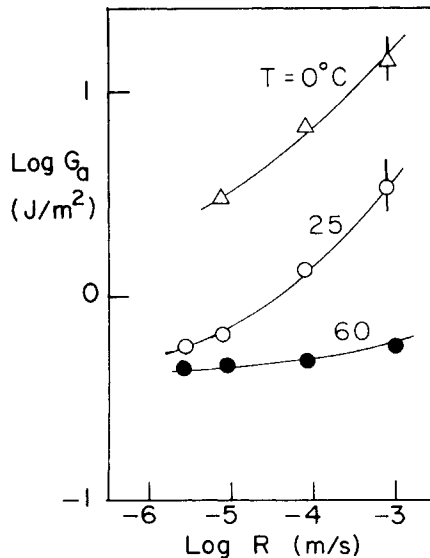

Fig. 8. Detachment energy  $G_a$  for a 25/75 PVC/DOP gel adhering to a Mylar substrate plotted against the rate  $R$  of advance of the line of separation.

Turning now to the slope  $m = 2.25 \pm 0.25$  of the experimental relation between  $\log$  (threshold fracture energy  $G_c$ ) and  $\log$  (concentration  $c$  of PVC in the gel) (Fig. 7), we note that of the two parameters that govern the fracture energy: number of effective strands per unit volume and average length of a strand: only the first is important in determining the modulus  $E$ .<sup>8</sup> Now the observed dependence of modulus upon concentration is stronger (Fig. 3),  $E \propto c^3$ , suggesting that the number of effective strands per unit volume is also proportional to  $c^3$ . Thus, the average length of a network strand appears to decrease as the concentration of PVC is increased, roughly in proportion to  $1/c$ .

This implies that crystallite sequences per molecule are more frequent in gels having a higher PVC concentration. But the reinforcing effect of crystallites have not been taken into account in this comparison. If there is, instead, a *constant* spacing of crystallite sequences, corresponding to a constant molecular strand length in the gel, independent of PVC concentration, then the dependence of modulus  $E$  and threshold fracture energy  $G_{c,0}$  upon concentration should be the same. The difference observed in practice must then be attributed to a stiffening effect of the crystallites present without a correspondingly large enhancement of fracture energy.

**Adhesion of PVC Gels to Mylar.** Experimentally determined values of the detachment energy  $G_a$  for a 25/75 PVC/DOP gel adhering to a Mylar substrate are plotted in Figure 8 against the rate  $R$  of peeling. As shown in Figures 9 and 10, measurements at different temperatures were again found to superpose when replotted against the effective rate  $Ra_T$  of peeling at the glass transition temperature  $T_g$  for the gel in question, where  $a_T$  is calculated by

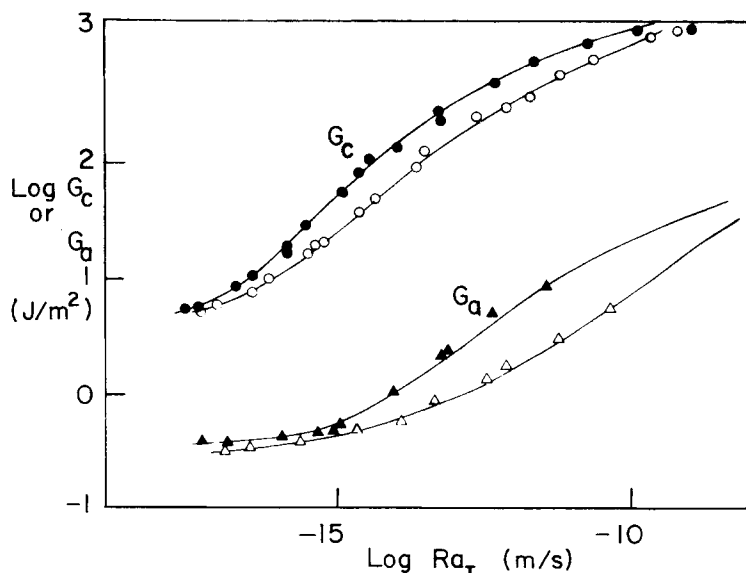

Fig. 9. Master relations for the detachment energy  $G_a$  plotted against the effective rate  $Ra_T$  of advance of the line of separation at  $T_g$  for a 25/75 PVC/DOP gel (filled-in symbols) and a 25/75 PVC/TCP gel (open symbols) adhering to a Mylar substrate. Master relations for the fracture energy  $G_c$  taken from Figure 6 are shown for comparison.

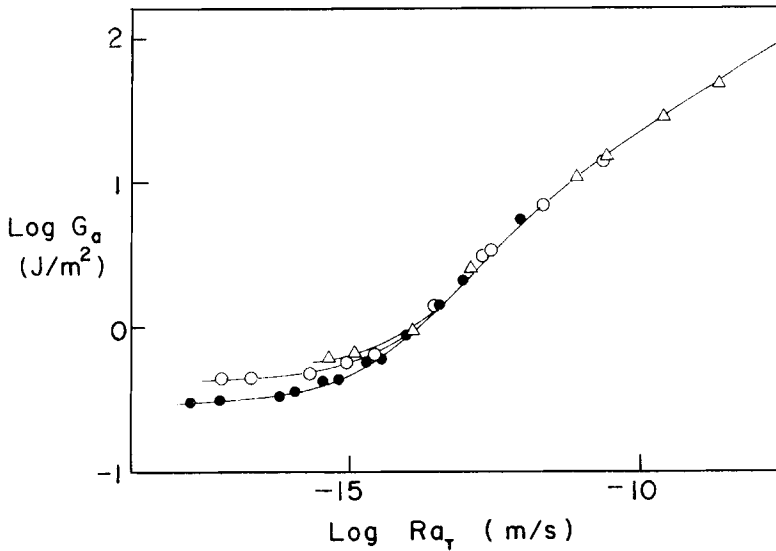

Fig. 10. Master relations for the detachment energy  $G_a$  plotted against the effective rate  $Ra_T$  of advance of the line of separation at  $T_g$  for PVC/DOP gels of various volume concentrations  $c$  of PVC adhering to a Mylar substrate.  $c = 0.15$ ,  $\bullet$ ;  $c = 0.25$ ,  $\circ$ ;  $c = 0.5$ ,  $\Delta$ .

means of Eq. (4). Indeed, the results for detachment energy  $G_a$  closely resembled those for fracture energy  $G_c$ . Numerically, the values were considerably smaller, being about 1/20 to 1/100 times the corresponding values of  $G_c$ , but their dependence upon rate of crack propagation and upon temperature is obviously similar for gels made with different plasticizers (Fig. 9), and with various amounts of the same plasticizer (Fig. 10). We now point out the less obvious ways in which the two sets of measurements differ.

First, there is a significant difference in the range of rates over which the detachment energy increases substantially (Fig. 9). These rates are about  $100 \times$  to  $1000 \times$  larger than the corresponding rates for fracture energy  $G_c$  (Fig. 9), suggesting that the characteristic distance over which viscoelastic dissipation is important is considerably larger in peeling than in tearing experiments. In detachment, the principal dissipation mechanism may be irreversible bending of the peeling strip, in which case the important dimension is the strip thickness. In tearing, on the other hand, dissipation at the crack tip may be dominant and the corresponding dimension would then be the crack tip diameter. Under threshold conditions, this distance would be only of molecular dimensions, corresponding to one or two network strand lengths, and dissipative effects would then be expected to appear at lower rates of tearing, as is observed.

**Threshold Values of Detachment Energy  $G_a$ .** A second difference between tear energies and detachment energies is the way in which their threshold values depend upon the concentration  $c$  of PVC in the gel. As discussed earlier, threshold values of tear energy appear to increase in proportion to  $c^{2.25}$ . Threshold values of detachment energy, obtained by extrapolating experimental relations such as those shown in Figure 10 to zero rate of peeling, are plotted in Figure 11 against  $c$  using logarithmic scales for both

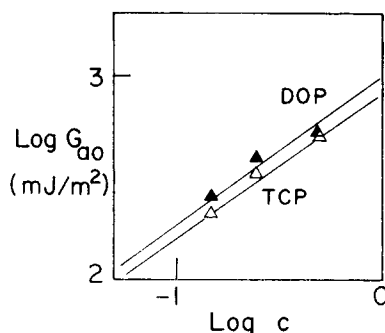

Fig. 11. Threshold value of the energy  $G_a$  required to detach a PVC gel from a Mylar substrate plotted against the volume concentration  $c$  of PVC in the gel.

axes. They are seen to be consistent with a simple proportionality to  $c$  for gels made with two plasticizers (although it should be noted that the threshold values were extremely small, only about 200–500 mJ/m<sup>2</sup>, and difficult to measure with much accuracy).

By extrapolation to the undiluted state,  $c = 1$ , values of threshold energy of detachment of about 1 J/m<sup>2</sup> are obtained. Similar values have been reported previously for lightly crosslinked elastomers in contact with rigid substrates, in the absence of any interfacial interlinking.<sup>5,13</sup> Thus, PVC gels do not appear to form any type of strong association with a Mylar substrate, and the low value of detachment energy under threshold conditions is further reduced by dilution with plasticizer.

### CONCLUSIONS

(i) The stiffness of PVC gels depends strongly upon the amount of plasticizer incorporated but relatively little upon the type of plasticizer used. Under quasiequilibrium conditions, the tensile modulus  $E$  is related to the volume concentration  $c$  of PVC in the gel as follows:

$$E(\text{MPa}) = 14c^3$$

(ii) Network strands thus appear to be unusually short, only about 26 main-chain atoms in an undiluted gel, if the stiffening effect of crystallites is ignored.

(iii) The tear strength of PVC gels depends strongly upon the rate of tearing and temperature in good agreement with the WLF rate-temperature equivalence. Apparently, the principal effect of the type and amount of plasticizer incorporated is to determine the glass transition temperature  $T_g$ .

(iv) At low rates of tearing and high temperatures a minimum (threshold) tear strength  $G_{c,0}$  is attained which depends strongly upon the concentration  $c$  of PVC in the gel:

$$G_{c,0}(\text{J/m}^2) = 135c^{2.25}$$

but not significantly upon the type of plasticizer used.

(v) An undiluted gel is thus unexpectedly strong, particularly in view of the inferred short length of network strands. This anomalous strength is attri-

buted, at least in part, to yielding of crystallites before molecular rupture occurs.

(vi) PVC gels are found to adhere weakly to a Mylar surface, with a threshold value for the detachment energy of less than  $1 \text{ J/m}^2$ .

(vii) Again, the detachment energy increases as the rate of detachment (peeling) is increased and the temperature is reduced, in good agreement with the WLF rate-temperature equivalence, but this enhancement takes place at significantly higher effective rates of detachment than the corresponding increase in tear strength.

This work was started while one of the authors (A. N. G.) was a Guest Worker at the National Bureau of Standards, January–May, 1984. Acknowledgment is due to Dr. L. C. Smith, head of the Polymers Division and Dr. D. L. Hunston, head of the Composites Section, for their kind hospitality during this stay. Mr. N. Shimizu is indebted to Denki Kagaku Kogyo K. K. for the grant of a leave of absence during the period 1983–85 in order to carry out research in polymer science at the University of Akron.

### References

1. A. T. Walter, *J. Polym. Sci.*, **13**, 207–228 (1954).
2. S. J. Guerrero and A. Keller, *J. Macromol. Sci.-Phys.*, **B20**, 167–184 (1981).
3. R.-J. Roe, K. J. Smith, Jr., and W. R. Krigbaum, *J. Chem. Phys.*, **35**, 1306 (1961).
4. R. S. Rivlin and A. G. Thomas, *J. Polym. Sci.*, **10**, 291–318 (1953).
5. A. Ahagon and A. N. Gent, *J. Polym. Sci.: Polym. Phys. Ed.*, **13**, 1285–1300 (1975).
6. G. W. Bullman and D. L. Hunston, Office of Naval Research Contract N00014-82-F-0052, Progress Report, July 7, 1982, Polymers Division, National Bureau of Standards, Washington, D.C.
7. L. Mullins, *J. Appl. Polym. Sci.*, **2**, 257–263 (1959).
8. L. R. G. Treloar, *Physics of Rubber Elasticity*, 2nd. ed., Clarendon Press, Oxford, 1958.
9. L. Mullins, *Trans. Instn. Rubb. Industr.*, **35**, 213–221 (1959).
10. J. D. Ferry, *Viscoelastic Properties of Polymers*, 2nd. ed., Wiley, New York, 1970.
11. F. Bueche, *Physical Properties of Polymers*, Interscience, New York, 1962.
12. A. N. Gent and R. H. Tobias, *J. Polym. Sci.: Polym. Phys. Ed.*, **20**, 2051–2058 (1982).
13. R.-J. Chang and A. N. Gent, *J. Polym. Sci.: Polym. Phys. Ed.*, **19**, 1619–1633 (1981).

Received March 3, 1986

Accepted March 24, 1986